

PERFORATING MACHINE C -169



Perforating Machine C - 169

Perforating machine for round drippers

- Drill speed: up to 500 drippers/minute
- Minimum distance between drippers: 20 cm (optional 15 cm)
- Electronic drill adjustment for pipe length
- Dripper distance statistics and updated distance display
- Faulty tolerance distance alert; dripper shortage alert
- Synchronized pulse output to quality control camera; camera indication of drill quality
- Coil stopper output option
- Alarm sound option
- Optional group drilling
- Mechanic dripper recognition
- Up to 4 drills at a time per dripper
- Friendly, localized user interface and unit control
- Machine's body made of stainless steel

3-phase current, 16 amp, 7-bar air pressure

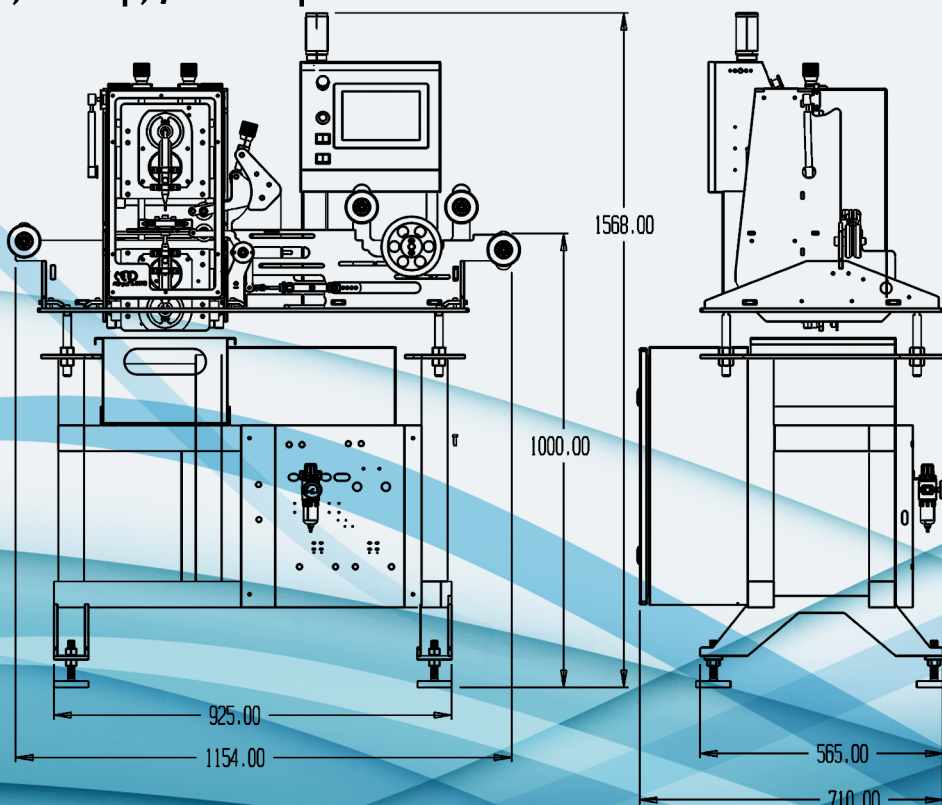

Mopline Macshevet LTD.
Moshav Merhaviya, Israel

+972-4-6420446
+972-50-5364697

office@mopline.com
www.mopline.com