

PERFORATING MACHINE F-170



Perforating Machine F -170

Perforating machine for flat drippers

- Drill speed: up to 1000 drippers/minute
- Minimum distance between drippers: 10 cm
- Electronic drill adjustment for pipe length; mechanic adjustment for pipe width
- Dripper distance statistics and updated distance display
- Faulty tolerance distance alert; drifter shortage alert
- Synchronized pulse output to quality control camera; camera indication of drill quality
- Coil stopper exit option
- Alarm sound option
- Optional group drilling
- Two drifter recognition sensors: mechanic for wide-edged pipes, laser for narrow-edged pipes
- Friendly, localized user interface and unit control

3-phase current, 16 amp, 7-bar air pressure

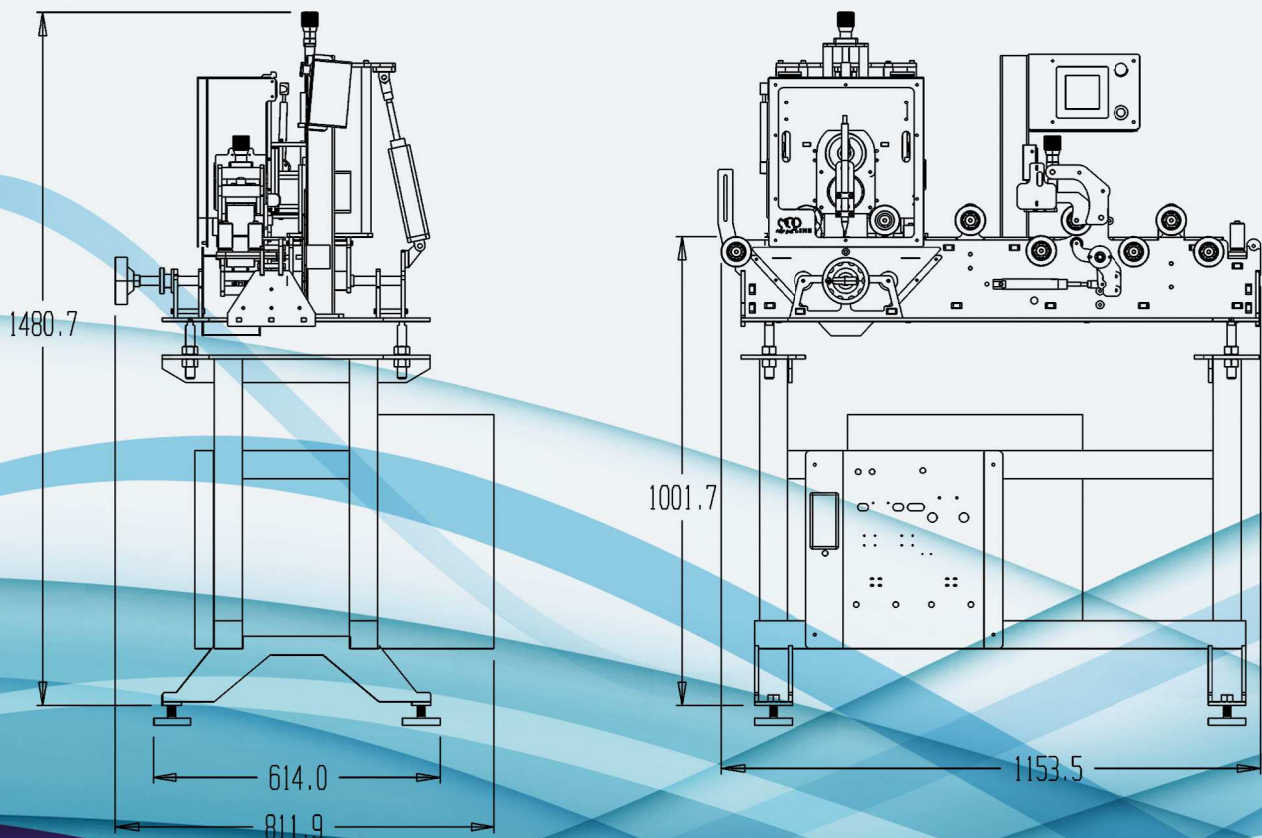

Mopline Macshevet LTD.
Moshav Merhaviya, Israel

+972-4-6420446
+972-50-5364697

office@mopline.com
www.mopline.com