

INSERT MACHINE I-1090



Insert Machine I-1090

Insert machine for flat drippers

- Insert speed: approximately 450 drippers/minute (varies by drip)
- Suitable for line speeds of up to 150 m/minute
- Friendly, localized user interface and unit control
- Synchronized with production line, can enter and exit line via electric piston
- Automatic stop and retreat in case of line malfunction

System includes:

- 1000 mm gauge bowl feeder
- Connective conveyor
- Computerized insert system
- Dripper elevator

3-phase current, 10 amp, 7-bar air pressure

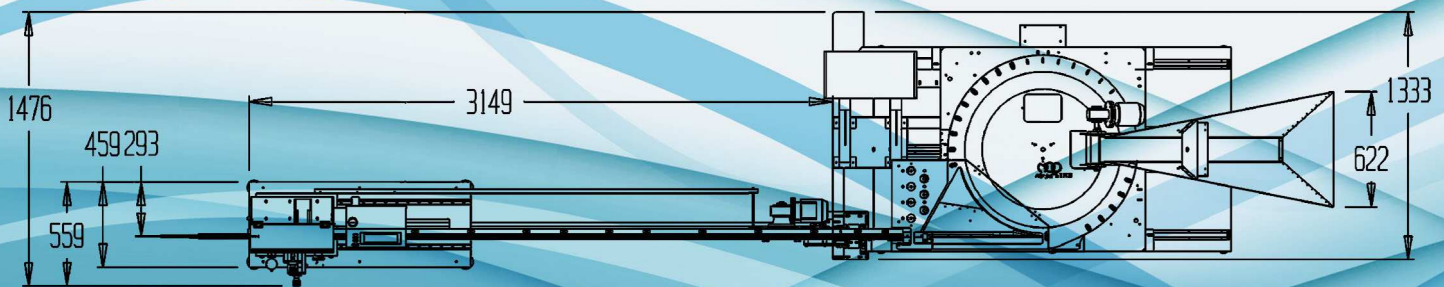
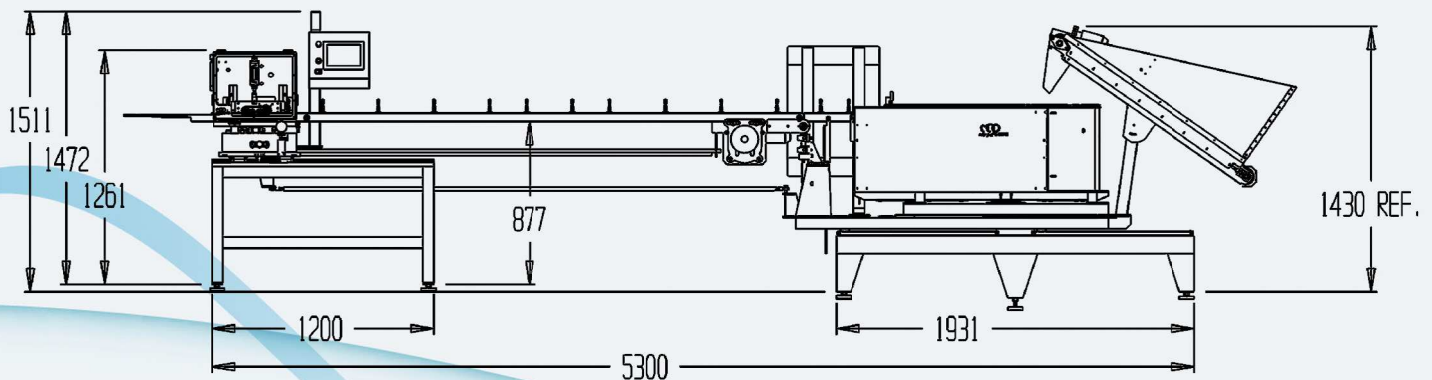

Mopline Macshevet LTD.
Moshav Merhaviya, Israel

+972-4-6420446
+972-50-5364697

office@mopline.com
www.mopline.com