

INSERT MACHINE I-1110

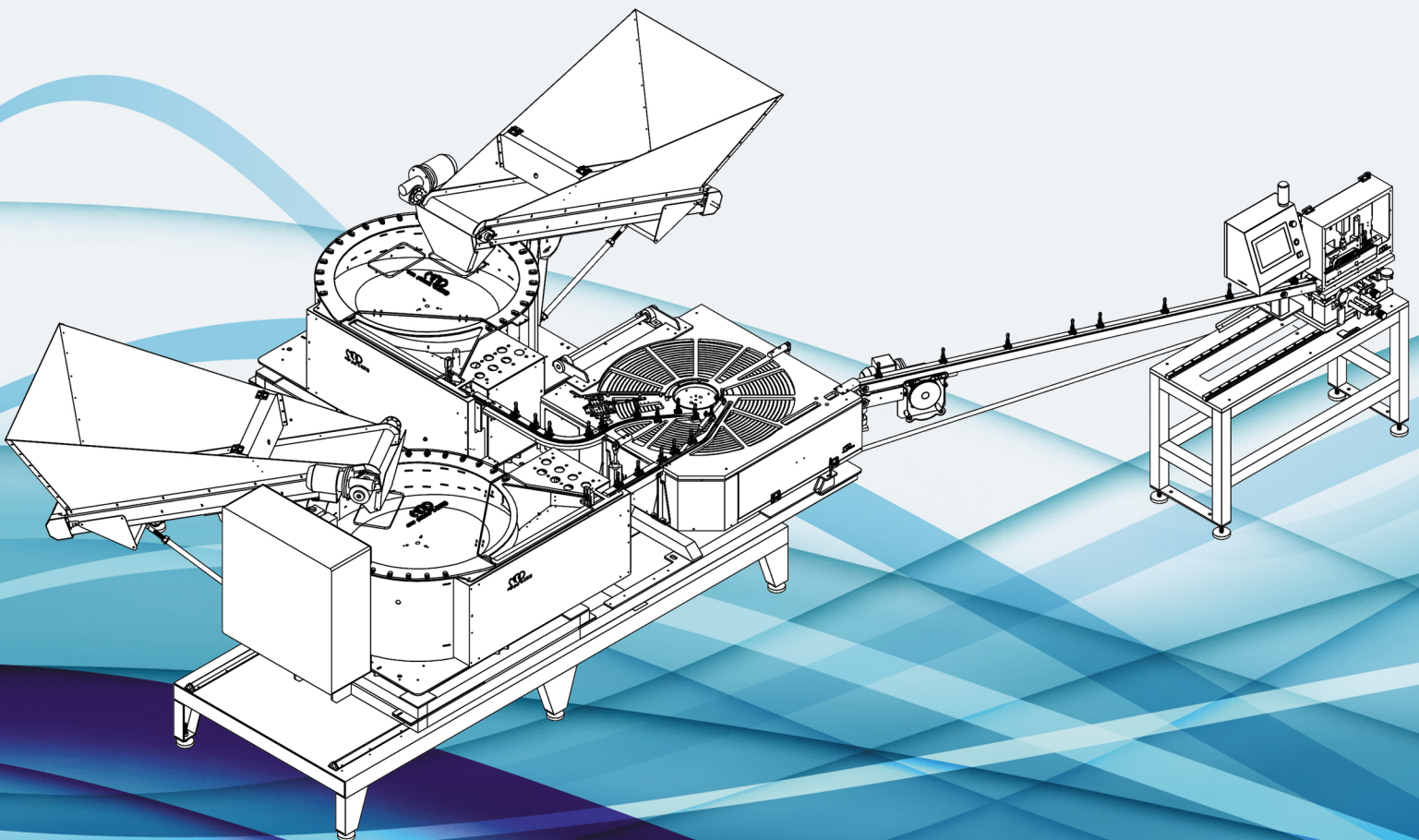

Insert Machine I-1110

Insert machine for flat drippers

- **Insert speed:** approximately 1400 drippers/minute for assymetric dripper.
1800 drippers/minute for symetric dripper,
for mini symetric dripper - faster than 1800 drippers/minute (varies by drip).
- Suitable for line speeds of up to 300 m/minute
- Friendly, localized user interface and unit control
- Synchronized with production line, can enter and exit line via electric piston
- Automatic stop and retreat in case of line malfunction

System includes:

- Two 1000 mm gauge bowl feeders
- 23 m accumulator
- Connective conveyor
- Computerized insert system
- Two Dripper elevators

3-phase current, 10 amp, 7-bar air pressure

Dimentions of this machine depends on available space at customer's place.



Mopline Macshevet LTD.
Moshav Merhaviya, Israel

+972-4-6420446
+972-50-5364697

office@mopline.com
www.mopline.com